



Livestock Disinfection

Using Thermal Fogging Equipment

pulsFOG®



All rights reserved 1-4-2009

AEROSOLSYSTEMS



Livestock Disinfection Using Thermal Fogging Equipment

For years, those working in the poultry industry have been conscious of the disease hazards which livestock are exposed to when housed. They are aware that there are numerous ways in which dangerous microorganisms can multiply. Dangerous situations very often go unnoticed, only to be discovered too late to avert losses.

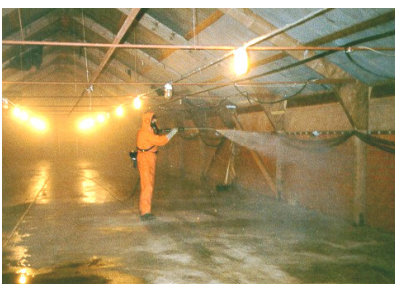

Removing deposits of excrement, stale food, mucus, blood and other debris from soiled surfaces by manual or mechanical means decreases the multiplication of microorganisms. However, these

shoveling, sweeping and washing operations are normally confined to floor and low wall level. This is not enough to completely disinfect buildings.

Due to the physical difficulties involved, the tops of walls, trusses and other overhead sections of buildings are often not effectively cleaned. Rodents, bats, birds, insects and other vermin frequently use the overhead sections of buildings. This causes this area to become contaminated, yet it goes untreated during routine cleaning. Stockmen often worry about this untreated area but are of the opinion that they are unable to do much about it. They know that contaminated air is a serious threat, and problems associated with temperature control and ventilation often create further difficulties. The pulsFOG® generators are designed to convert solutions

into ultra-fine droplets, which the machines then disperse evenly throughout the building being treated.

The droplets remain suspended in the air before they impinge on surfaces to form a deposit. This aerosol method of applying disinfectants not only deposits active product on surfaces, including those which are inaccessible, but it does so very quickly. This means that it has the advantage of saving labour as well as being efficient.

The pulsFOG® thermal foggers have great discharge rates, delivering fog at a range of 20 to 70 m. Fogging of a building is often done through an open door or outside hatch. The operator works the machine from the outside. Choosing the size and performance of equipment has to be based on requirements.



Aerosol Experience

Ultra low volume techniques used for applying agricultural chemicals have been in use for a number of years and the fate of discharged droplets formed from different liquids and active ingredients have been studied. Pure water as fogging carrier has been found to evaporate too quickly, particularly in the case of very small droplets. For this reason, formulators developed special ultra low volume formulations that eliminate or reduce the use of water as a fogging carrier for the disinfectant or insecticide.

For many years, highly concentrated biocides have been effectively dispensed as Ultra Low Volumes in the field of Plant Protection using special machine techniques and discharge nozzles. The same principle is now being applied to disinfectants.

This makes it necessary for the dilution rates recommended by disinfectant suppliers to be adjusted. In most cases the re-adjustment may only necessitate reducing the water being added because the ingredient in use already

has a very low volatility (e.g. glutaraldehyde); in others, incorporating an additive with the water solution will be advisable to prolong the lifespan of the discharged droplet by delaying its evaporation. An additive approved for use with disinfectants is available under the trade name **pulsFOG® VK-2 Spezial**.



Disadvantage of High Volume Application

Mixing disinfectants with the water used to clean buildings inevitably leads to a loss of disinfectant because not only is the solution soiled when used for cleaning, but a vast quantity of it is lost in the drains. Disinfectants that flow into the sewage systems together with the water used for cleaning destroy the putrefactive bacteria and obstruct the biological cleaning effect in purification plants.

Advantage of ULV Application

Saves time and labour. A stable of 1000 m³ can be treated within 15 min when using a middle-sized pulsFOG® machine (e.g. a type K-22) and a disinfectant usually applied 1 % in water (High volume).

Applying disinfectants in aerosol form, however, is not intended as an alternative to other cleaning methods. It is intended to improve upon the normal treatment and compliment the stockman's fight against transmittable diseases.

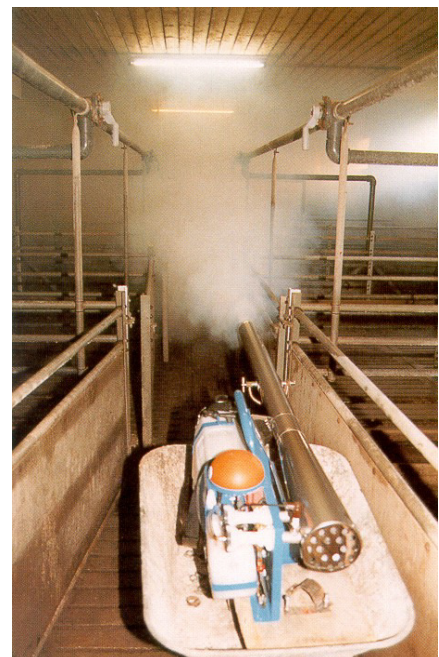

AEROSOLSYSTEMS



pulsFOG®
K-30-O

pulsFOG®
K-22-O

pulsFOG®
K-10-O

pulsFOG®
K-10-SP

PulsFOG
Turbo ULV

pulsFOG® K-30-20-O

Thermal Fogger for Ground Disinfection

Using a flame head as an extension at the fogging pipe, the fogger can be used for effective ground disinfection, provided the ground and walls are made from concrete or non-inflammable material.



Thermal Fogger for the Aerosol Disinfection

pulsFOG® Thermal foggers are applied in the low-volume process, i.e. the products are fogged with reduced solution quantities, but higher concentration. Thermal foggers produce droplets with an average size of 10 µm. The result is an almost dry application. Since the products are dispersed evenly, an

excellent surface treatment is achieved, even in inaccessible places, such as Ventilation shafts. Aerosol disinfection is therefore a space application with volume and surface effect.

Disinfection by fogging is carried out from an open doorway into the room, depending on the size of the stable and the fogger to be used. For a proper machine run, the rear part of the engine with the carburettor must be located in an area of the room containing fresh air.



Application from outside to inside

Thermal Fogging with Formalin

15-20 l of a 40% Formalin solution is required to fog a room of 1.000 m³. The range of the fog can be 70 m and more, dependent on the fogger's performance.

Advantage: highly effective!

Disadvantage:

- Increased health risk during the application due to the toxicological characteristics of Formalin.
- Only suited for larger and consequently more expensive fogger types.
- Minimum fogging time: 20 min/ 1.000 m³

Thermal Fogging with Brand Products

The advantage of using brand disinfection products in comparison with Formalin are evident:

- Low dosage and therefore a quicker fogging term.
- Use of smaller machine size and consequently lower cost of purchase.
- Lower toxicity risk during application for the operator.

AEROSOLSYSTEMS



Fogging aldehydes in empty stable immediately after wet cleaning



Insecticide fogging in pig stable

Dosage of Chemical

The solution quantity of a brand product when used with pulsFOG® is determined on the basis of the spraying concentration with hydraulic sprayers (High Volume):

Concentration in wet spraying method (HV)	1%	2%	3%	Fog throwing range in meters
Quantity of Product for pulsFOG® /1000 m³ (litres)	1,5 -2	3-4	4,5 -8	
+ water (litres)	4	5	6	
+ additive VK-2 Spezial (litres)	0,5	0,5	0,5	
= Total/1000 m³ (litres)	6-6,5	8,5-9,5	11-14,5	
Fogging period with pulsFOG® Thermal Foggers	min	min	min	m
K-10	30	45	55-70	25
K-22	18	27	33-52	50
K-30	6	9	11-14	70

Disinfection Chain:

1. Insect Control

Before cleaning the stable, i.e. immediately after having emptied the building, while it is still warm, a short application of an insecticide

such as a pyrethroid (e.g. Deltamethrin) is recommended in order to control the hidden pests and disease-causing agents. Since these pests will have left the farm building when it has cooled down, pest control must be executed immediately after the stable has been emptied.

2. Cleaning

Dirt reduces the effectiveness of the applied disinfection products considerably. It is therefore important to clean all stable surfaces and related equipment with great care before disinfecting. To this end all animals and mobile Installations must be removed.

3. Main Disinfection

In order to achieve the most effective disinfection result, it is advisable to start the disinfection operation immediately after the wet cleaning procedure while the floor, walls and roof are still wet. Wet surfaces allow the deep penetration of settled aerosols into absorbing materials and cracks.

4. Second Disinfection

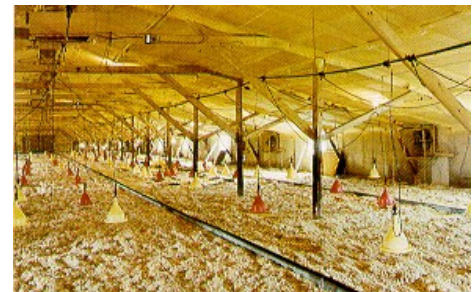

In case of epidemic or when stables are too close to one another, a second disinfection is useful on all cleaned, reinstalled and mobile equipment (animals not yet inside) in order to reduce germination within this equipment. Thermal fogging for 2. disinfection is carried out **from outside to inside** through a hole, window or the door in order to avoid any risks of accidents.



The noisy thermal fogging machine is not used to apply disinfectants to or over animals. For this application electrical mist applicators such as the TURBO ULV or the Rapid- Fogger are available.



Use of the portable thermal fogger pulsFOG K-22/O

General Features of Aerosol Disinfection:

- Strongly reduced solution quantities that reduce time and chemical costs considerably, particularly effective through its ultra fine droplets, smaller than 10 µm, they disperse spontaneously throughout the whole area and disinfect even inaccessible corners and cracks (ventilation shaft) etc.
- Protection of sewage works.
- No drain loss of disinfectants with the water.
- Considerably saving of material during the fogging process.
- Ideal for all disinfection products that are effective in a gaseous phase (peroxyacetic acid, aldehydes, phenols) and even biological products based on fruit acids have shown excellent results.
- Treats the whole area, including all surfaces.
- Makes work easier for personnel and protects their health, since the application is carried out from the outside.

- Can even be applied as second disinfection of the new floor and all equipment (troughs and tubs) that has been brought back.

Economy

Insect pests in factory farming can survive more than a year and are immensely dangerous for young cattle. Disinfection has to be considered as a necessary investment for more economic stock breeding. Calculations made by competent specialists have demonstrated that the costs for cleaning and disinfection are balanced out by fundamentally better breeding results. Food exploitation is improved and the mortality has decreased considerably.

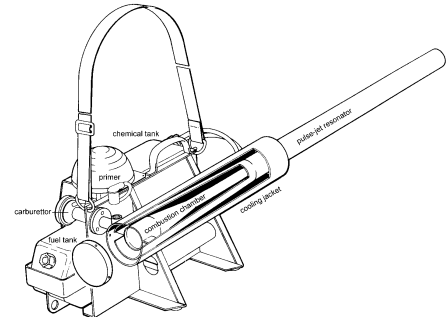

Functioning of Thermal Fog Generator

What distinguishes the propulsion engine (pulse-jet) from a standard engine?

The propulsion engine does not contain any moving parts necessary for the functioning of a standard engine. The bottle-shaped combustion chamber is then empty and leads directly into the exhaust pipe. A floating membrane attached to the carburettor ensures the controlled pulsating combustion in the combustion chamber with an adjustable cycle of 80-100 explosions/s. Right from the start, the exhaust is as clean as that of a car with a catalyst motor designed to protect the environment. The spark plug is only needed for the first explosion. From then on, the pulsating combustion continues automatically. As there are no moving parts, fuel consumption can be seen as a reliable measure of the performance of a fogger of this type.

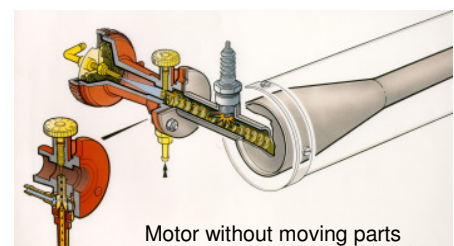

Motor without moving parts

How are the Droplets Formed?

The fogging solution is injected into the exhaust of the resonator at the far end of the fogging pipe. The kinetic energy present in the escaping gas (at a speed of 15 - 20 m/s) breaks the injected liquid into droplets of varying size. The principle thus approximately resembles that of a pneumatic spraying machine. However, as there is heat energy in the region of 500 - 800 kcal per 1 l fogging solution present at the same time, even smaller droplets are formed and they evaporate partially depending on their size and chemical composition. When the conditions permit a complete or partial evaporation, then we have a so-called "condensation fog". This fog develops a short distance from the fog pipe by sudden contact with the surrounding cooler air. The influence of the heat is of so short a duration that a negative effect on the active ingredients need not to be of concern.



Useful Accessories:

- | | |
|--|---|
| (1) pulsFOG® protection suit | (6) Solution funnel, small |
| (2) pulsFOG® mixing set:
graduated
1 x 2 l + 250 ml
graduated measure
1 pair of chemical
gloves | (7) pulsFOG® tool bag |
| (3) Cleaning kit filled with
5 l REIN | (8) Cleaning borer for nozzle
cane |
| (4) Fuel pitcher | (9) Gas mask with filter
A ₂ B ₂ -P ₃ |
| | (10) Cleaning brush cpl. with
stick |
| | (11) Ear protection |
| | (12) Spare parts bag, small |
| | (13) Spare parts bag, large |



pulsFOG® Dr.Stahl & Sohn GmbH

Abigstrasse 8 • D-88662 Überlingen • Phone ++49 7551 / 9261-0 • Fax ++49 7551 / 926161
E-Mail: info@pulsFOG.com • www.pulsFOG.com